

System: Laufschiene eingetuet, keine Nut im Boden ohne Blende, Laufwerk für verdeckte Montage, für 2 Holztüren bis 15 kg. Design Inslide

System: Top track, groove mounted, no groove in the floor, without fascia, with groove mounted running gear for concealed fixing, for 2 wooden doors up to 15 kg. Design Inslide

Système: Rail de roulement dans rainuré, aucune rainure dans le sol, sans cache, avec chariot de roulement pour montage caché, pour 2 portes en bois de 15 kg max. Design Inslide

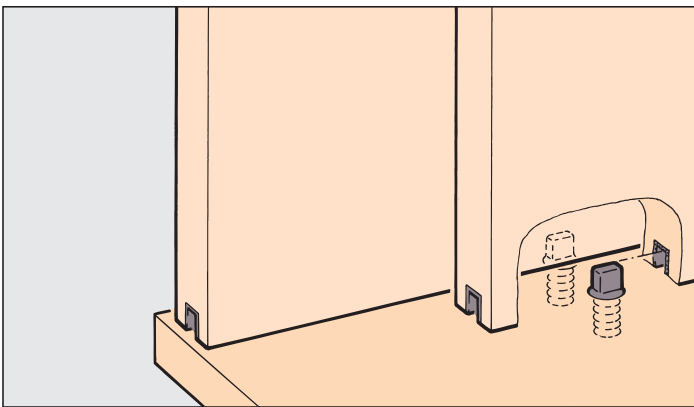

Bei zurückversetzter Seitenwand Stopper / Türmitnehmer unten setzen
 Where doors overlap side panels, set stopper / door follower at the bottom
 Placer la butée / entraîneur en bas si la paroi latérale de porte est décalée par rapport à la porte

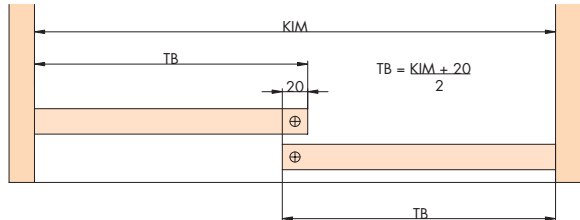

Einbaubeispiele / Mounting examples / Exemples de montage

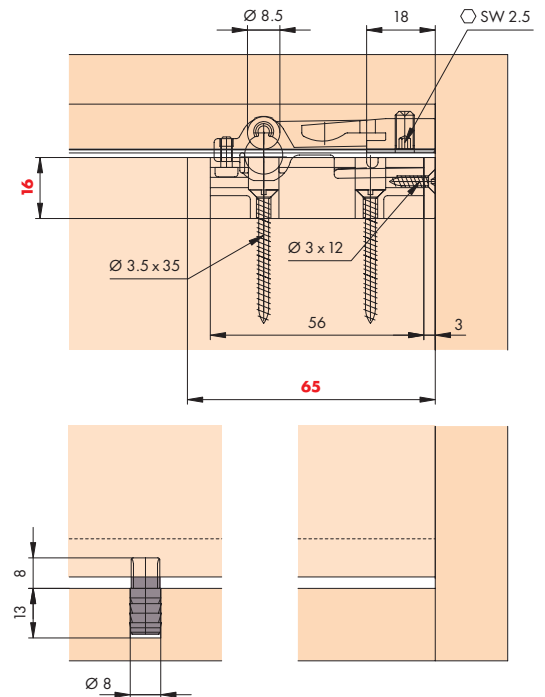
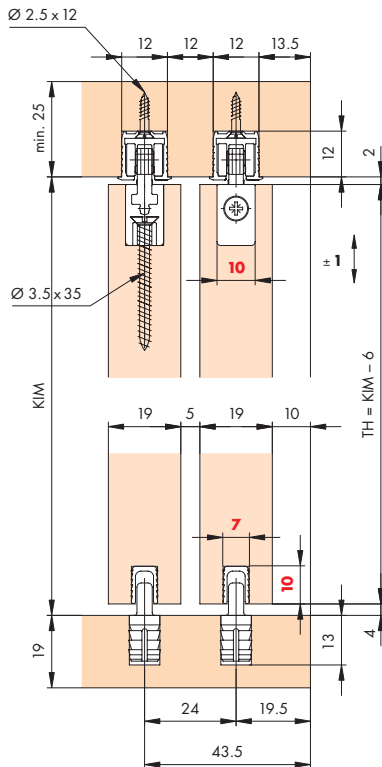
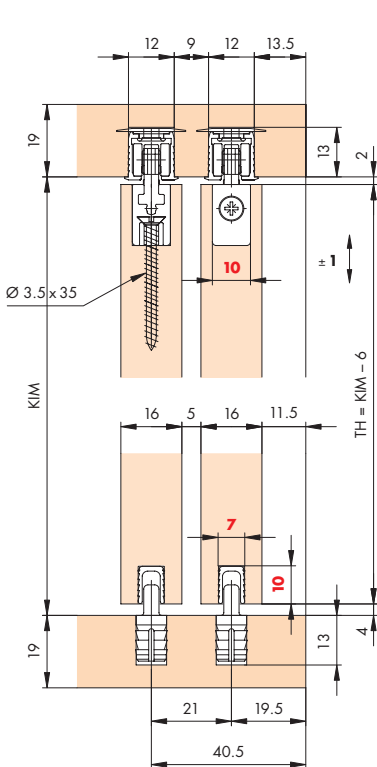
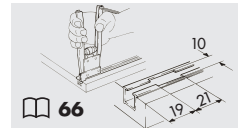

Befestigungsvarianten

Mounting options
Variantes de fixation

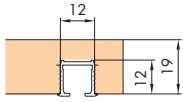

A zum Verstemmen oder Kleben
for press-fitting or glueing
à enfoncer ou coller

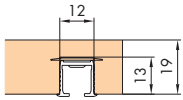

B mit Drehriegel (nicht für Hartholz/MDF)
with swivel lug (not for hard wood/MDF)
avec verrou (pas pour bois dur/MDF)

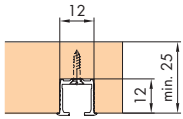

C zum Schrauben
screwed on
à visser

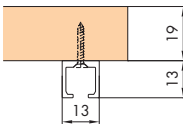







D zum Aufschrauben
surface mounted
à visser en applique

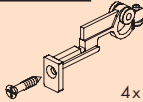

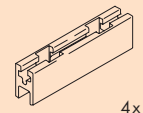
Türgewichte
Panel weights
Poids de portes **71**

Garnituren / Sets / Garnitures

2 Türen Doors Portes		No. 053.3022.071	
 4x	 4x	 4x	 2x
 4x			

Ideal für Durchreichen
Ideal for service hatches
Idéal pour passe-plaf

Zubehör / Accessories / Accessoires

	Gr./Size	Art. No.
A Einfachlaufschiene Alu, zum Verstemmen oder Kleben Single top track aluminium, for press-fitting or glueing Rail de roulement simple en alu, à enfoncer ou coller	2500 mm	053.3007.250
	3500 mm	053.3007.350
	6000 mm	053.3007.600
B Einfachlaufschiene Alu, mit Drehriegel (nicht für Hartholz/MDF) Single top track aluminium, with swivel lug (not for hard wood/MDF) Rail de roulement simple en alu, avec verrou (pas pour bois dur/MDF)	2500 mm**	053.3008.250
	3500 mm**	053.3008.350
	6000 mm	053.3008.600
C Einfachlaufschiene Alu, gelocht, zum Schrauben Single top track aluminium, pre-drilled, screwed on Rail de roulement simple en alu, perforé, à visser	2500 mm**	053.3009.250
	3500 mm**	053.3009.350
	6000 mm	053.3009.600
D Einfachlaufschiene Alu eloxiert, gelocht, zum Aufschrauben Single top track aluminium anodized, pre-drilled, surface mounted Rail de roulement simple en alu anodisé, perforé, à visser en applique	2500 mm	053.3035.250
	3500 mm	053.3035.350
	6000 mm	053.3035.600
Führungsschiene, Kunststoff anthrazit, 7 mm Guide track, plastic anthracite, 7 mm Rail de guidage, plastique anthracite, 7 mm	2500 mm	053.3012.250
	3500 mm	053.3012.350
	6000 mm	053.3012.600

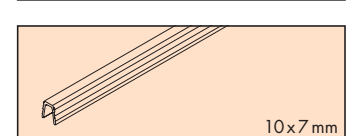
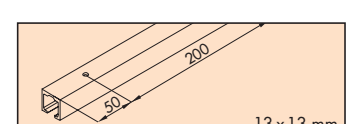
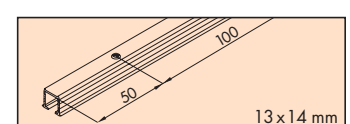
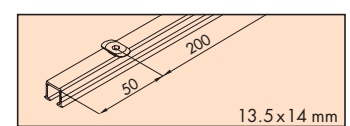
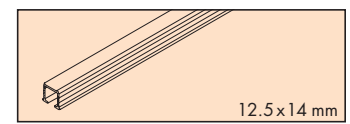

** beidseitig ausgeklinkt / notched on both ends / encoché des deux côtés